



Riley
communications

49 River Street
Old Saybrook, CT 06475

(860) 510-0873

FAX (860) 510-0874

www.rileycomms.com

e-mail: cgoff@rileycomms.com

Following is a sample of the cover and three inside pages of an 8-page brochure describing a unique, patented coaxial connector for use on printed-circuit boards. This connector design allows instrumentation design engineers to make their products smaller, more manufacturable, and less expensive.

Client: Applied Engineering Products
New Haven, CT

Call us if you'd like a printed copy, or get more information on these products at www.aepconnectors.com

This page illustration © Riley communications 1999.

Following pages © Applied Engineering Products 1999.

All Rights Reserved.

**All images are digitally watermarked
to ensure traceability.**

SLB/SA

Self-Aligning P.C. Board Connectors

- Eliminate inter-board cable assemblies
- Ideal for daughtercard applications
- Simplify modular designs
- Save time, space, and expense

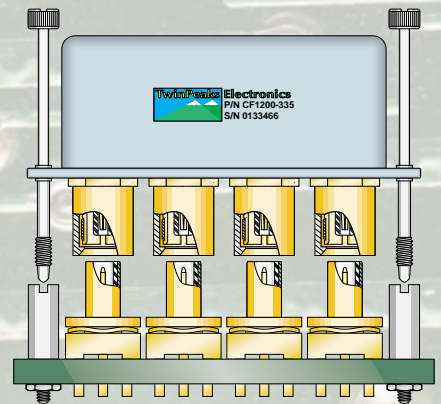
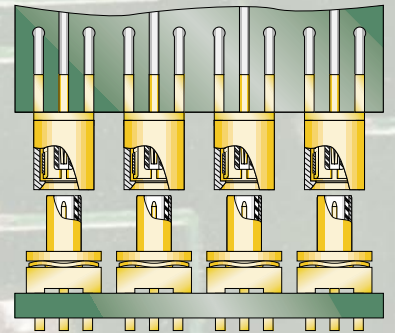
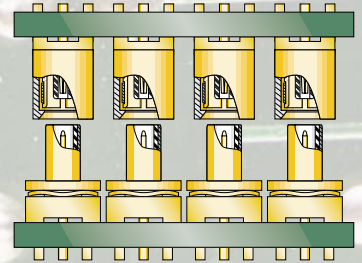
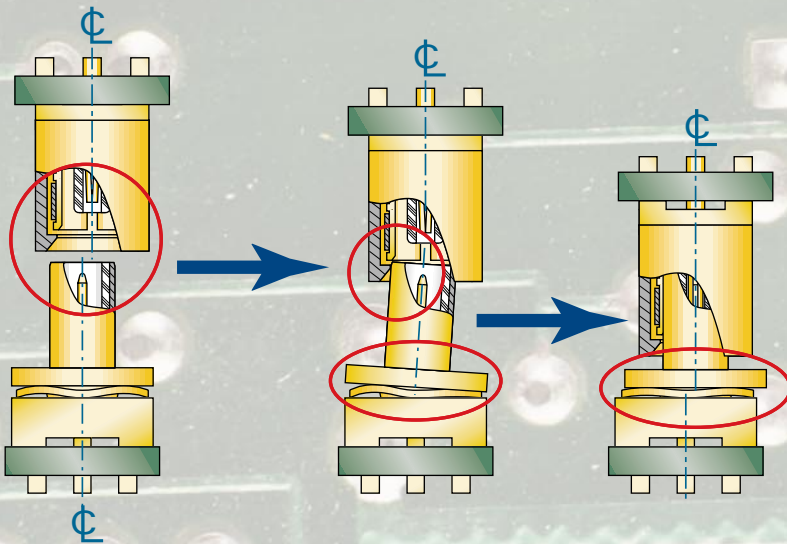

AEP **APPLIED
ENGINEERING
PRODUCTS**
Performance, not promises

(203) 776-2813 • FAX (203) 776-8294

www.aepconnectors.com

e-mail: aepsales@aepconnectors.com

104 John W. Murphy Drive, New Haven, CT 06513

ISO 9001 CERTIFIED

Applications

When you need to move RF or shielded signals from one P.C. board to another, **SLB/SA** connectors allow you to plug the boards directly together—no more expensive cable assemblies needed to compensate for connector misalignment.

Customizing your products with pluggable modules is easy, too. And downloading data from logging instrumentation can be simpler and more reliable.

The possibilities are almost endless. Here are just a few ways that **SLB/SA** connectors can help make your products simpler, smaller, and more versatile. If you don't see what you need, call us—our engineers are ready to help with your requirements.

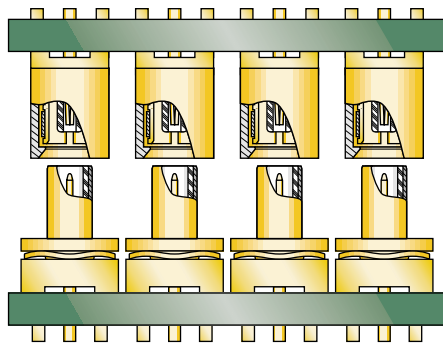

Stacked P.C. board configuration, using straight mating plugs with through-hole mounting (3025 series).

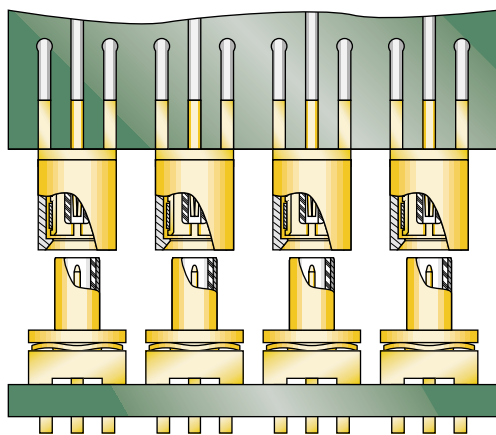

Daughterboard configuration, using straight edge-mount mating plugs (3025 series).

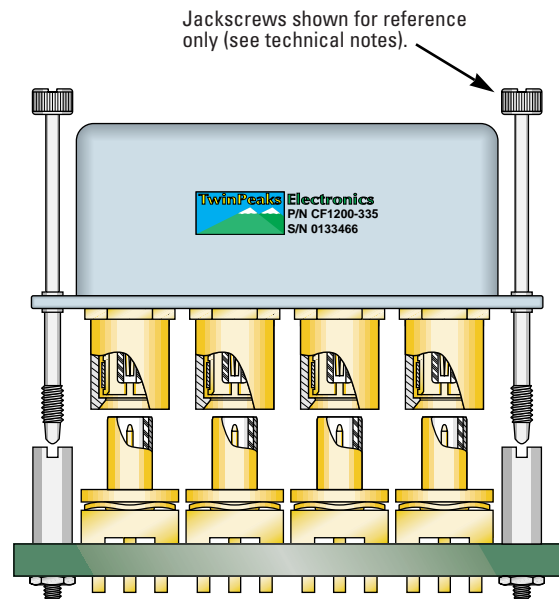

Modular component to motherboard, using straight bulkhead-mounted mating plugs (3017 series).



Self-Aligning P.C. Board Jack

Through-hole mounting, stepped legs: 3509-1511-000

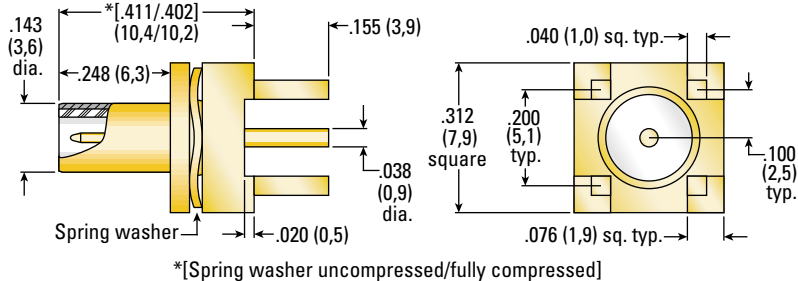

Dimensions in inches (mm).

Range of movement (floating front end)

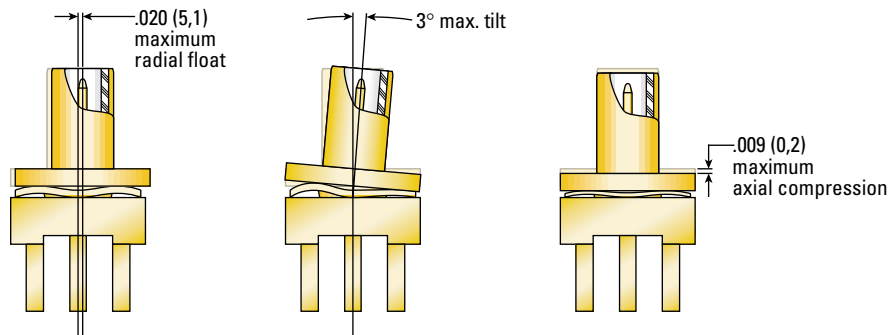

Dimensions in inches (mm).

Interface dimensions and specifications

Interface dimensions

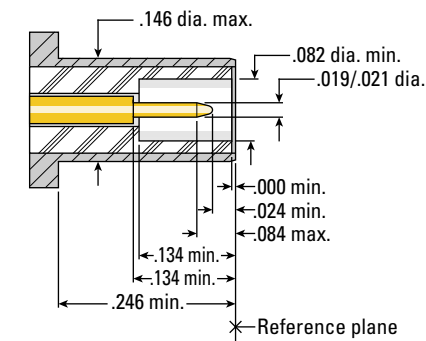

Dimensions in inches.

SLB/SA PCB Jack Specifications

Materials:

Body components, center contacts: Brass per ASTM-B-16, Alloy 360, 1/2 hard.

Springs: Stainless steel.

Insulators: Teflon (TFE) per ASTM-D-1710.

Finish:

All metal parts: Gold plated per MIL-G-45204.

Electrical:

Impedance: 50Ω.

Frequency range: DC-6 GHz.

Voltage Rating: 335 VRMS @ sea level.

VSWR: 1.15:1 maximum to 6 GHz.

Insertion Loss: .2 dB maximum @ 6 GHz.

Contact Resistance: *Center contact:* 0.3 ohms maximum.

Outer contact: 4.0 milliohms maximum.

Dielectric Withstanding Voltage: 1,000 VRMS @ sea level.

Corona level: 230VRMS @ 70,000 ft.

Insulation Resistance: 1,000 megohms minimum.

Mechanical:

Force to engage and disengage: 1.5 pounds average per mated pair.

Contact retention: 4 pounds minimum axial force.

Durability: 500 mating cycles.

Environmental (MIL-STD-202):

Temperature range: -65° C to +165° C.

Corrosion: Method 101, condition B, 5% salt solution.

Vibration (Method 204): Condition B.

Mechanical shock (Method 213): Condition B.

Thermal shock (Method 107): Condition B.

See pages 4 and 5 for mounting dimensions, application notes, and electrical performance charts.



Application Notes

Mounting, spacing, and tolerances

P.C. board drilling dimensions

(for 3509-1511-000 and 3025-1511-011)

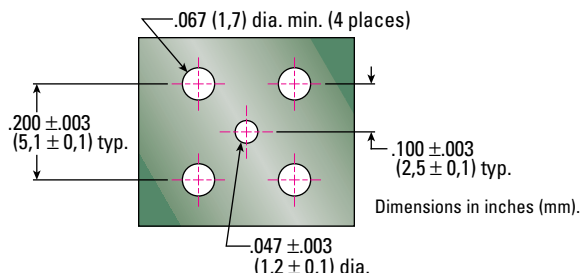

Mounting tolerances

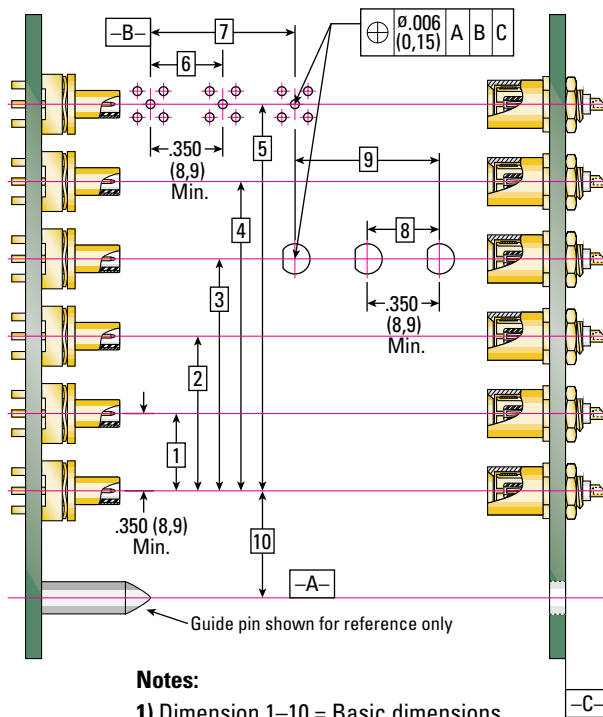

Application Notes

Mating forces:

Average mating force of 1.5 pounds per mated pair has been tested and shown to be linear up to 12 mated pairs of connectors, and is unaffected by connector misalignment within the specified mounting tolerances per the specifications drawing on this page.

External P.C. board hardware:

External hardware for guiding the boards into proper mating alignment and for preventing unmating of board pairs must be incorporated into final designs. The design of this fixturing hardware should be based on the requirements of your specific application.

The connectors themselves should **not** be used to guide the boards into proper alignment during mating, nor should the unmating force of the connectors be relied upon to hold the boards together after mating.

Mounting surface deflection:

In all applications, consideration should be given to the modulus of elasticity of the boards or panels on which the connectors are mounted. If the total mating force of the connector pairs exceeds the stiffness of the boards or panels, bending of the boards or panels will occur, and will be most severe at the center of the row or array.

In such cases, electrical performance can be significantly degraded due to incomplete mating of the connector pairs in the affected area.

Board spacing for selected applications

*[Spring washer uncompressed/fully compressed.]

Dimensions in [inches] (mm).

Daughterboard configuration, using 3509-1511-000 and 3025-1511-014 or -016

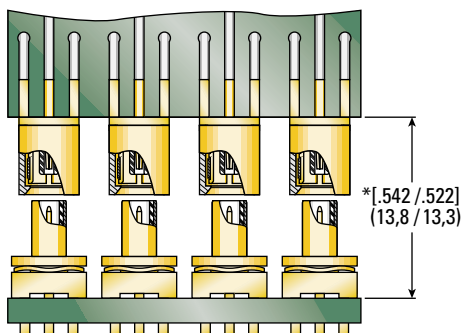

Stacked P.C. board configuration, using 3509-1511-000 and 3025-1511-011

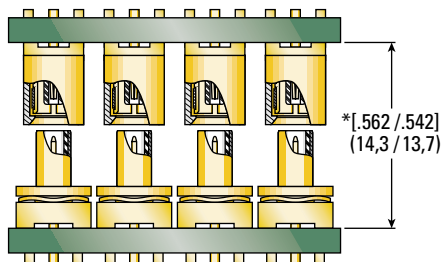

Modular component to P.C. board, using 3509-1511-000 and 3017-1511-005

